

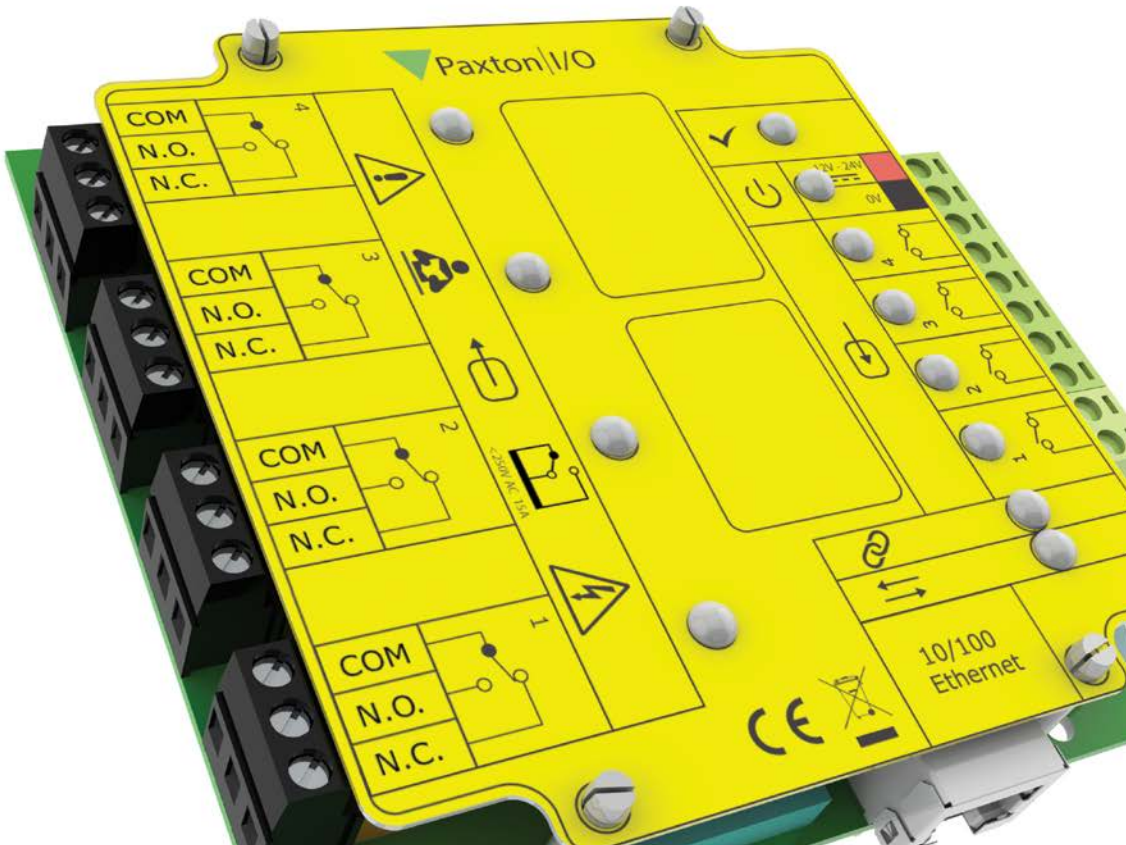

ins-20005

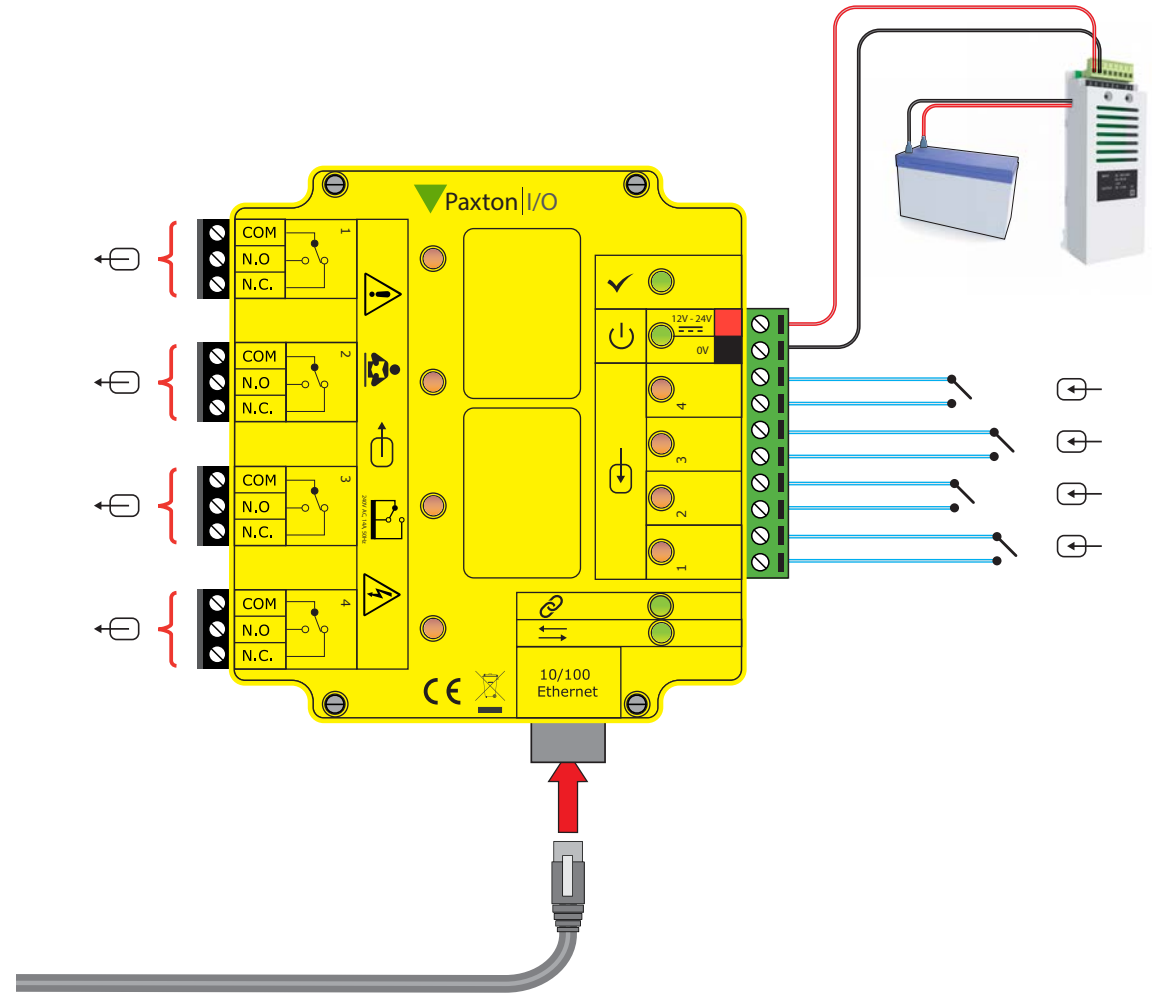

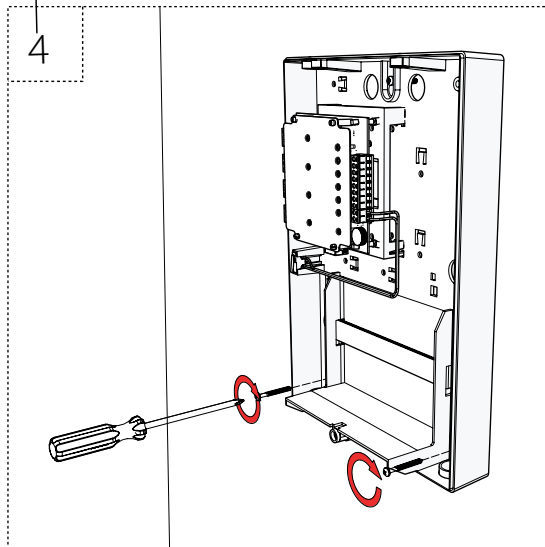
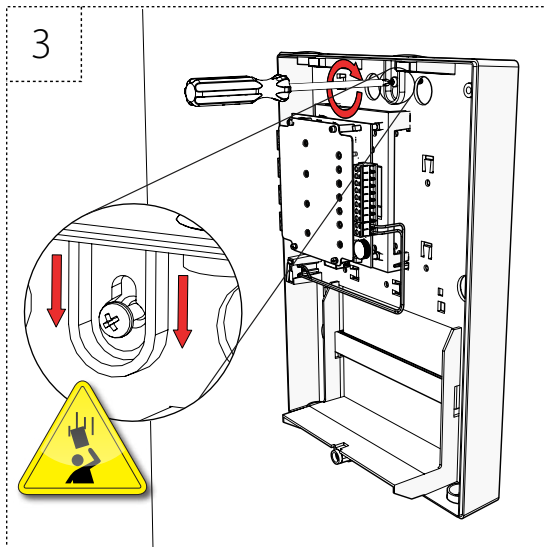
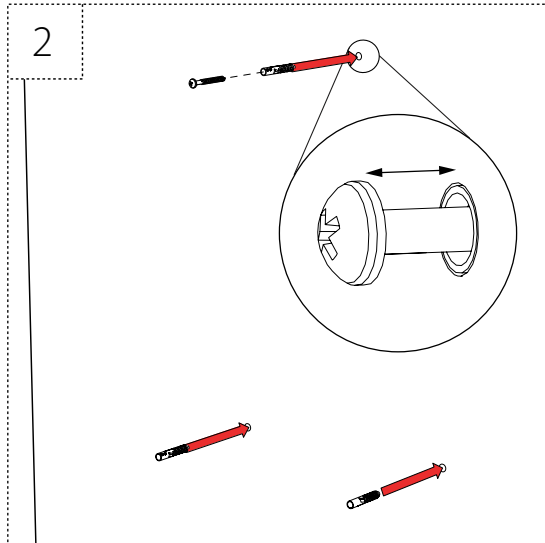
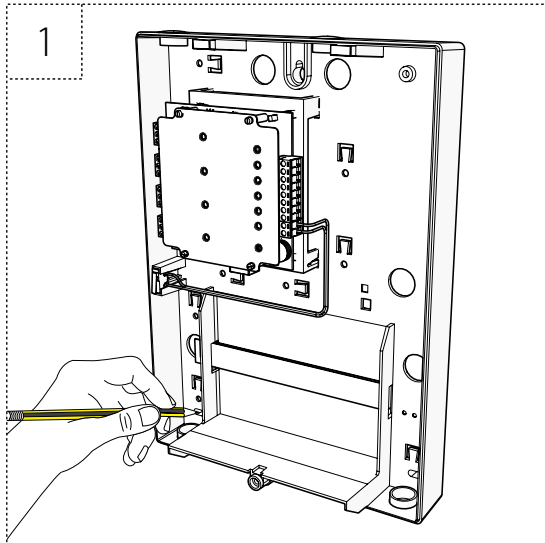

385-710

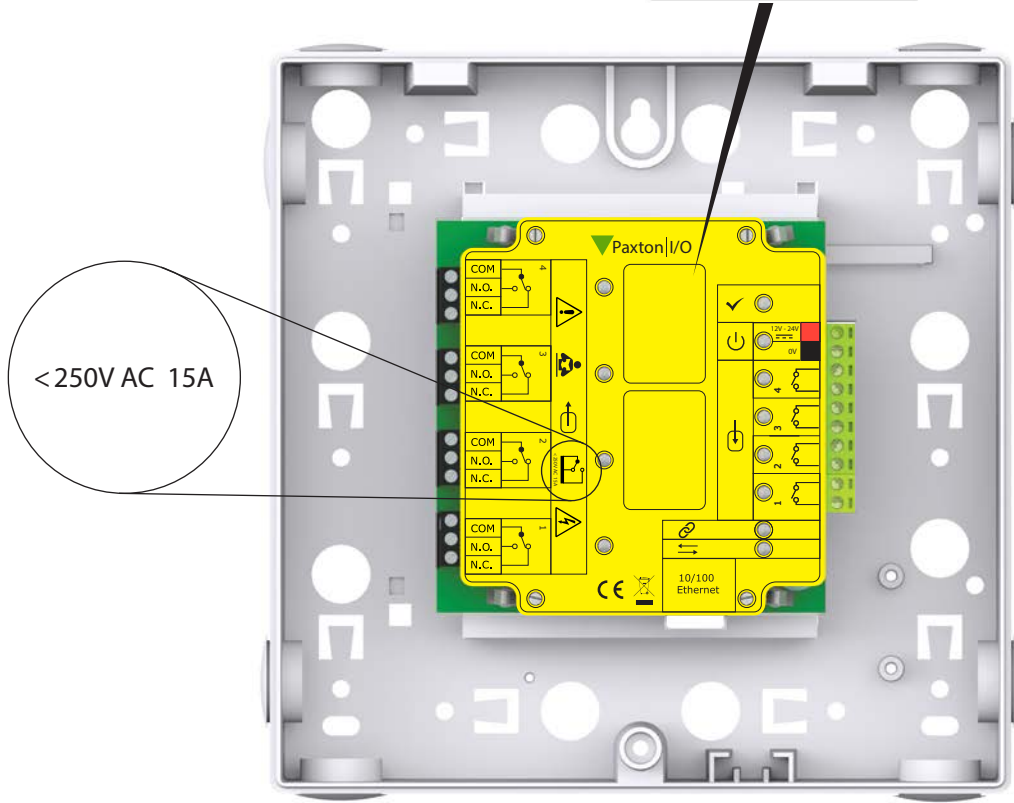

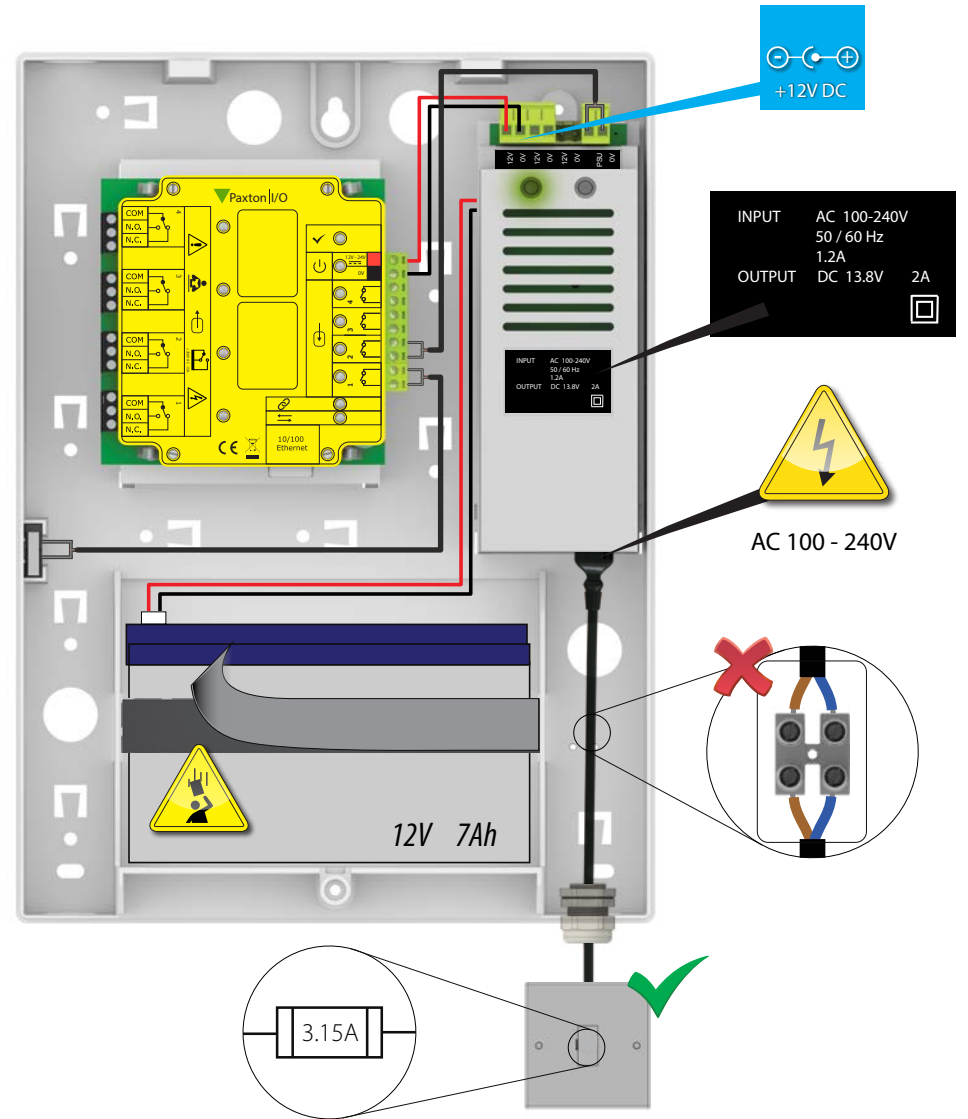

12V	
400mA	
<a href="http://paxton.info/107">http://paxton.info/107</a>	
<b>Model No: 385-710DV</b>	
Complies with part 15 of the FCC rules. This Class A digital device complies with Canadian ICES-003.	

411-623

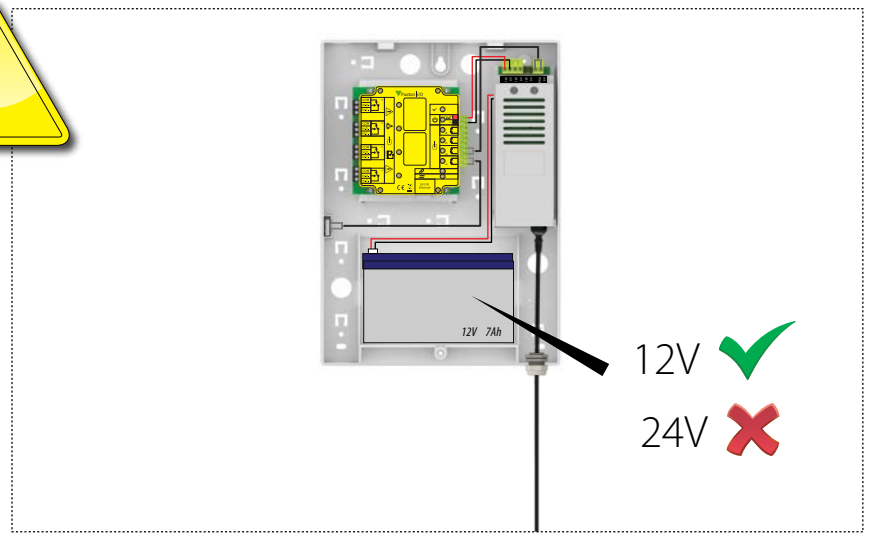
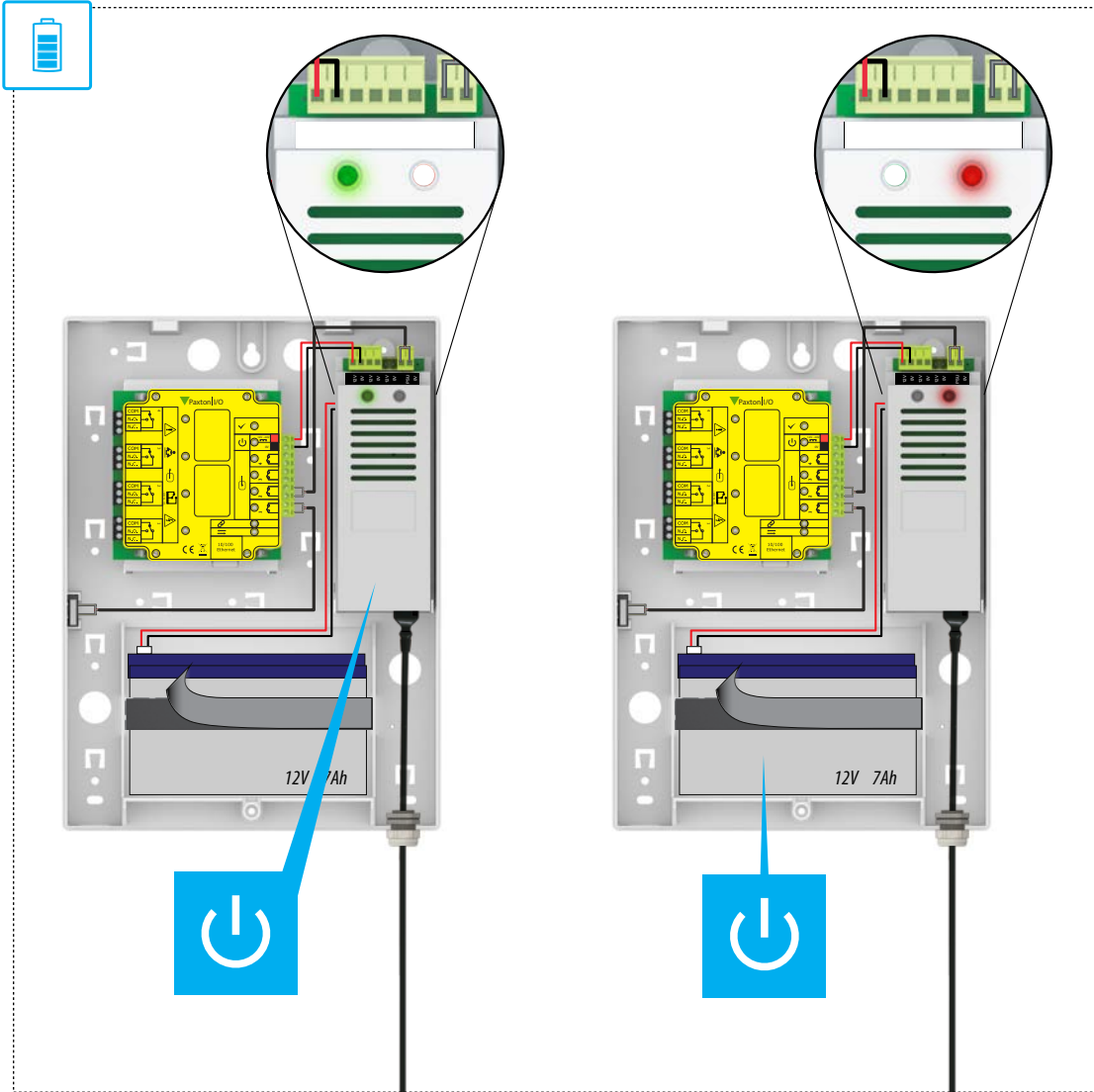

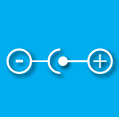

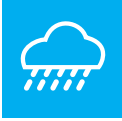
	 @12V DC			
385-710	400mA	15A 240V AC	↑ -20°C - +55°C -4°F - +131°F ↓	×
411-623	400mA	15A 240V AC		×
489-710	400mA	15A 240V AC		×



+44 (0)1273 811011  
 support@paxton.co.uk  
 paxton.support



+1(800) 672-7298  
 supportUS@paxton-access.com  
 usapaxton.support



+31 (0)76 3333 999  
 support@paxton-benelux.com  
 paxton.benelux.support



+49 (0) 251 2080 6900  
 support@paxton-gmbh.de  
 paxton.gmbh.support



+33 (0)157 329356  
 support@paxtonaccess.fr  
 paxton.support



+27 (0) 272 14276691  
 support@paxtonaccess.co.za  
 paxton.support



8000 3570 3783  
 support@paxtonaccess.ae  
 paxton.support



+1 (864) 751-3501  
 soporte@paxton-access.com  
 paxton.soporte



+44 (0)1273 811011  
 support@paxton.co.uk  
 paxton.support



The declaration of conformity is available on request. Contact details are provided at: <http://paxton.info/596>

These products are not suitable for retail sale. All warranties are invalid if these products are not installed by a competent person.

The product is compliant with the following directives:

- The Low Voltage (LVD) Directive
- The Electro-Magnetic Compatibility (EMC) Directive
- The Restriction of Hazardous Substances (RoHS) Directive

**The following warnings and instructions MUST be adhered to. Read the instructions before installing and powering the equipment. Keep the instructions in a safe place for future reference.**

**INSTALLATION** - Only qualified and trained personnel, familiar with this type of product and who fully understand these instructions should install, connect or test this equipment. There are no user serviceable parts within the PSU unit.

- The equipment is intended for indoor use only in dry locations. This is a Class A product. In a domestic environment this product may cause radio interference in which case the user may be required to take adequate measures.

- The installation must meet National Wiring Regulations and IEC60950-1 standards.

- Disconnect Devices: A readily accessible disconnect device shall be incorporated in the building wiring to include an appropriately rated circuit breaker to disconnect both poles with at least a 3.0 mm contact gap. After switch off, all internal capacitors will discharge to safe levels within 60 seconds under normal conditions. Under fault conditions, charge may be held for much longer and suitable precautions should be taken before handling the unit.

- Protection device: The fusing characteristics of the protection device to be used are T3.15AH250V

**SAFETY WARNING**

**RISK OF EXPLOSION IF BATTERY IS REPLACED BY AN INCORRECT TYPE.**

**DISPOSE OF USED BATTERIES ACCORDING TO THE INSTRUCTIONS.**

To prevent electric shock, do not remove the cover. This unit could contain hazardous voltages and should only be opened by a trained and qualified technician.

To avoid the possibility of electric shock, disconnect electric power to the product before connecting or disconnecting the cables.

Considerations shall be made with regard to fuse protection to output relays and equipment being driven by the relay.

This must be appropriate in terms of current rating and fusing characteristics for application, be high braking capacity and approved in accordance with IEC 60127 or an appropriate circuit breaker approved in accordance with IEC 60947.

Considerations shall be made with regard to fuse protection to output relays and equipment being driven by the relay

This must be appropriate in terms of current rating and fusing characteristics for application, be high braking capacity and approved in accordance with IEC 60127 or an appropriate circuit breaker approved in accordance with IEC 60947.

The installation must meet the requirements of National Wiring Regulations and IEC60950-1.

Mains cable shall be away from SELV cables unless mains wiring has a distance through insulation of 0.4 mm.

Only qualified Engineers should install and service this equipment.

Read the instructions before installing and powering the equipment. Adhere to all instructions or warnings. Keep the instructions in a safe place for future reference.

The cross sectional area of the cables should be within the parameters of acceptance for the terminal connectors and suitable for application.

The routing of the cables should be away from rough or sharp objects to avoid abrasion with no kinks and positioned to reduce strain.

Enclosures used must be selected with regard to Fire resistance to suit the end installation.

The equipment is intended for indoor use only in dry locations.

When the Net2 I/O board is supplied as a PCBA only, the host product shall comply with the following standards:

IEC 60950-1:2005 + A1:2009 + A2:2013  
EN 60950-1:2006 + A1 1:2009 + A1:2010 + A12:2011 + A2:2013  
UL 60950-1/R:2014-10  
CAN/CSA C22.2 No. 60950-1/A2:2014-10

Enclosures used must be selected with regard to Fire resistance to suit the end installation.

If the board is to be installed within a metal enclosure, consideration must be taken to ensure creepage and clearance distances are in accordance with the above standards.

Enclosures used must meet the opening, mechanical strength and stability requirements of the above standards.

Enclosure used shall require a tool for opening to protect users from hazardous voltages.

The host PSU must be capable of supplying 12VDC 400mA minimum. If the PSU is not a limited power source the enclosure shall have a flammability rating of 5VB.

Power supply length to be a minimum of 1.5m and a maximum of 4.5m to meet US/Canada requirements.

## North America:-

### Product Compliance and limitations

This device complies with Industry Canada licence-exempt RSS standard(s). Operation is subject to the following two conditions: (1) this device may not cause interference, and (2) this device must accept any interference, including interference that may cause undesired operation of the device.

Wiring methods shall be in accordance with the National Electrical Code (ANSI/NFPA70), local codes, and the authorities having jurisdiction.

### FCC Compliance

This device complies with Part 15 of the FCC Rules. Operation is subject to the following two conditions:

(1) this device may not cause harmful interference, and (2) this device must accept any interference received, including interference that may cause undesired operation. Changes or modifications not expressly approved by the party responsible for compliance could void the user's authority to operate the equipment.

Class A digital devices.

This equipment has been tested and found to comply with the limits for a Class A digital device, pursuant to part 15 of the FCC Rules. These limits are designed to provide reasonable protection against harmful interference when the equipment is operated in a commercial environment. This equipment generates, uses, and can radiate radio energy and, if not installed and used in accordance with the instruction manual, may cause harmful interference to radio communications. Operation of this equipment in a residential area is likely to cause harmful interference in which case the user will be required to correct the interference at his own expense.

Wiring methods shall be in accordance with the National Electrical Code (ANSI/NFPA70), local codes, and the authorities having jurisdiction.

For CAN/ULC-S319 installations, terminals, leads and wiring methods must comply with CSA, C22.1, Canadian electrical code, Part 1, safety standards for electrical installations.

The use of any add-on, expansion, memory or other module manufactured or supplied by the manufacturer's representative will invalidate the CAN/ULC-S319 certification.

This device complies with Industry Canada licence-exempt RSS standard(s). Operation is subject to the following two conditions: (1) this device may not cause interference, and (2) this device must accept any interference, including interference that may cause undesired operation of the device.

### Conformité et limitations du produit

Ce dispositif est conforme au(x) standards RSS de l'industrie Canadienne sans-licence. Le fonctionnement est soumis aux deux conditions suivantes : (1) ce dispositif ne doit pas créer d'interférences nuisibles et (2) ce dispositif doit accepter toute interférence reçue, y compris des interférences qui peuvent causer un fonctionnement non souhaité.

Les méthodes de câblage doivent être en accord avec le code nation électrique (ANSI/NFPA70), codes locaux et les autorités ayant la juridiction.

### Conformité FCC

Appareils numériques de classe A.

Cet appareil a été testé et a été trouvé conforme avec les limites pour un appareil numérique de Classe B, en vertu de la Partie 15 des règles FCC. Ces limites sont conçues pour fournir une protection raisonnable contre des interférences nuisibles dans une installation résidentielle. L'appareil génère, utilise et peut émettre une énergie de fréquence radio et, s'il n'est pas installé et utilisé en accord avec les instructions, peut causer des interférences nuisibles aux communications radio. L'opération de cet équipement dans une zone résidentielle créera probablement des interférences nuisibles dans quel cas l'utilisateur sera requis pour corriger l'interférence à ses frais.



Made in the UK

